



3-150.03 Swinghandle FS PrC for Insert



Avantages

- The locking cam is included.
- Version with cylinder cover is securable with wire padlock.
- IP65 according to DIN EN 60529 - version dish with cap.
- Dish with hook version is secured outside the sealed area.
- RH / LH application.
- Grounding by grounding clip (optional).

Materials

- **Swinghandle:** zinc die, chrome plated or black or PA, black
- **Dish:** PA, black

Notes

(S) Door-thickness 1.5 - 2.5mm
The swinghandles can be retrofitted with sliding cap product system 2-091.
Inserts must be ordered separately.



Swinghandle, dish PA, for insert

	Part Number	Handle material	Surface handle	Dish	IP protection	Cylinder cover material	Installation type	Delivery Unit
a)	107-9247.00-00000	zinc die	chrome plated	with cap	IP65		screw-on	1 pc.
a)	107-9246.00-00000	zinc die	black	with cap	IP65		screw-on	1 pc.
b)	107-9251.00-00000	zinc die	chrome plated	with hook			screw-on	1 pc.
b)	107-9250.00-00000	zinc die	black	with hook			screw-on	1 pc.
a)	207-9270.00-00000	PA	black	with cap	IP65		screw-on	1 pc.
a)	207-9271.00-00000	PA	black	with cap	IP65	PA	screw-on	1 pc.
b)	207-9272.00-00000	PA	black	with hook			screw-on	1 pc.
b)	207-9273.00-00000	PA	black	with hook		PA	screw-on	1 pc.

Function

+ extension

d) 3-011 **Grounding Clip Stainless Steel**

* Accessories

c) 2-141 **Inserts**

3-130 **Rod Latch FS PrC**

3-132.02 **Rod Latch RS PrC**

3-165 **Rod Latch FS PrC and Angle Pieces with Rollers**

3-170 **Rod Latch for Multi-Point Locking FS PrC**

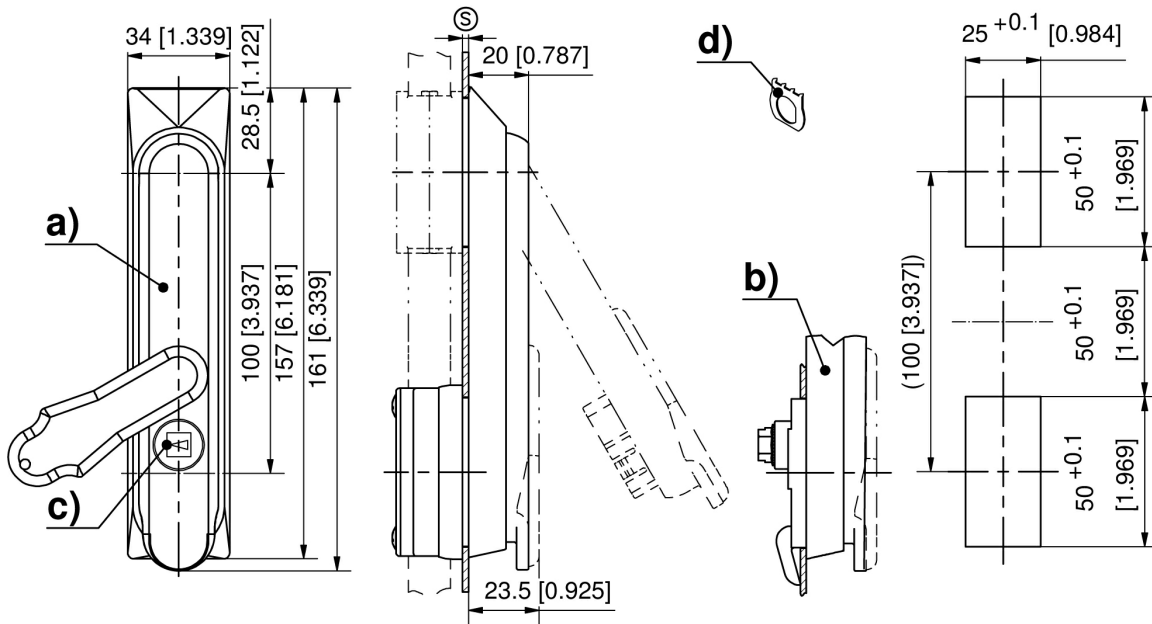



2-141 Inserts



Avantages

- Inserts with spring washer for swinghandle see product system 2-070, 2-080.01, 2-080.02, 2-090.03, 3-070, 3-155.02 and 6-111.02.
- Insert sets consist of insert and spring washer.

Materials

- **Insert:** zinc die, chrome plated
- **Wave washer:** spring steel, zinc plated

Notes

Suitable keys see product system 6-100 and 6-101.
For further versions please contact DIRAK.



Inserts

	Part Number	Insert	Delivery Unit
a)	211-9501.00-00000	Square 6mm	1 pc.
b)	211-9502.00-00000	Square 7mm	1 pc.
c)	211-9503.00-00000	Square 8mm	1 pc.
d)	211-9504.00-00000	Square 8mm, slotted	1 pc.
e)	211-9505.00-00000	Triangular 6.5mm CNOMO	1 pc.
f)	211-9506.00-00000	Triangular 7mm	1 pc.
g)	211-9507.00-00000	Triangular 8mm	1 pc.
h)	211-9508.00-00000	Triangular 9mm EDF	1 pc.
i)	211-9509.00-00000	Double bit 3mm pin	1 pc.
k)	211-9510.00-00000	Double bit 5mm pin	1 pc.
l)	211-9511.00-00000	Socket hex. 6mm	1 pc.
m)	211-9512.00-00000	Socket hex. 10mm	1 pc.
n)	211-9513.00-00000	Daimler Benz type	1 pc.
o)	211-9514.00-00000	Slotted 2x4mm	1 pc.
p)	211-9515.00-00000	Slotted recessed coinproof	1 pc.
q)	211-9516.00-00000	Crown type	1 pc.
r)	211-9517.00-00000	Square socket 6mm	1 pc.
s)	211-9518.00-00000	Square socket 7mm	1 pc.
t)	211-9519.00-00000	Square socket 8mm	1 pc.
u)	211-9520.00-00000	Half-round czech	1 pc.

