



# 7-081.02HD Hygiene Quarter-Turn with T-Handle Pr20.1 L18 Stainless Steel



## Avantages

- Tested according to: GS-NV 2:2013/06 principles for the testing of food processing machines, GS-NV 6:2013/06 principles for the testing of hygiene requirements. Machine Ordinance: DIN EN 1672-2:2009.
- DGUV Test Certificate.
- Dirt resistant and easy to clean by means of polished surface and transition radii.
- IP 65/67/69K according to DIN EN 60529 / DIN 40050.
- RH / LH application.
- Grounding by grounding nut.
- Cam can be delivered pre-assembled upon request.
- A pre-assembled quarter-turn can be installed in the cutout.

## Materials

- **Housing, handle and grounding nut:** AISI 316
- **Serrated screw:** AISI 304
- **Seal:** silicone, blue, FDA conform (Food and Drug Administration)

## Notes

- (S) Door-thickness max. 8mm  
Please configure the quarter-turn with a cam.  
1. silicone seal



## Hygiene Quarter-turn with T-handle

	Part Number	Housing length	Installation type	Delivery Unit
a)	100-9313.00-00000	18 mm	screw-on	1 pc.

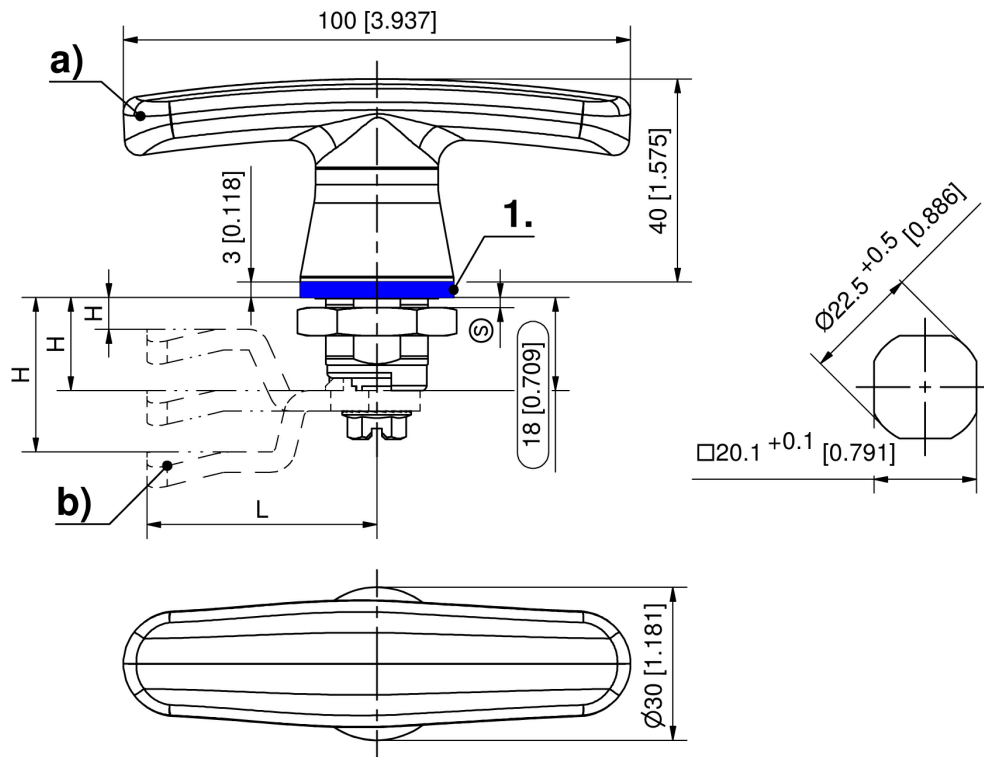



## 7-105 Cams L35/45 Stainless Steel



### Avantages

- Cams with ramp and stop with 35mm and 45mm length for 1-point locking.
- 3-point cam for 3-point locking.
- 2-point cam as rod control for 2-point locking.

### Materials

- **Cams:** AISI 304

### Notes

Slide shoe for cams 35 and 45mm, see product system 1-103

1. ramp 3mm
2. stroke 18mm
3. stubs for c-clips included



## Cams, L45

Part Number	H-dimension GI18	H-dimension GI30	H-dimension GI36	H-dimension GI40	H-dimension GI50	H-dimension GI60	Delivery Unit
200-0506.00-00000	6 mm	18 mm	24 mm	28 mm	38 mm	48 mm	1 pc.
200-0508.00-00000	8 mm	20 mm	26 mm	30 mm	40 mm	50 mm	1 pc.
200-0510.00-00000	10 mm	22 mm	28 mm	32 mm	42 mm	52 mm	1 pc.
200-0514.00-00000	14 mm	26 mm	32 mm	36 mm	46 mm	56 mm	1 pc.
200-0516.00-00000	16 mm	28 mm	34 mm	38 mm	48 mm	58 mm	1 pc.
200-0518.00-00000	18 mm	30 mm	36 mm	40 mm	50 mm	60 mm	1 pc.
200-0520.00-00000	20 mm	32 mm	38 mm	42 mm	52 mm	62 mm	1 pc.
200-0522.00-00000	22 mm	34 mm	40 mm	44 mm	54 mm	64 mm	1 pc.
200-0524.00-00000	24 mm	36 mm	42 mm	46 mm	56 mm	66 mm	1 pc.
200-0526.00-00000	26 mm	38 mm	44 mm	48 mm	58 mm	68 mm	1 pc.
200-0528.00-00000	28 mm	40 mm	46 mm	50 mm	60 mm	70 mm	1 pc.
200-0532.00-00000	32 mm	44 mm	50 mm	54 mm	64 mm	74 mm	1 pc.
200-0540.00-00000	40 mm	52 mm	58 mm	62 mm	72 mm	82 mm	1 pc.
200-0542.00-00000	42 mm	54 mm	60 mm	64 mm	74 mm	84 mm	1 pc.
200-0550.00-00000	50 mm	62 mm	68 mm	72 mm	82 mm	92 mm	1 pc.

## Cams, L35

Part Number	H-dimension GI18	H-dimension GI30	H-dimension GI36	H-dimension GI40	H-dimension GI50	H-dimension GI60	Delivery Unit
200-4535.00-00018	18 mm	30 mm	36 mm	40 mm	50 mm	60 mm	1 pc.
200-4535.00-00020	20 mm	32 mm	38 mm	42 mm	52 mm	62 mm	1 pc.
200-4535.00-00022	22 mm	34 mm	40 mm	44 mm	54 mm	64 mm	1 pc.

## 3-point cam

Part Number	Version	Delivery Unit
200-9845.00-00022	Bending A20	1 pc.
200-9845.00-00028	Bending A26	1 pc.

## 2-point cam

Part Number	Delivery Unit
200-9899.00-00000	1 pc.

